

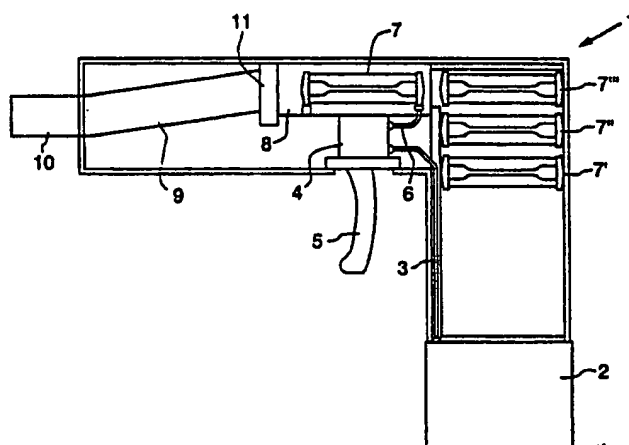

INTERNATIONAL APPLICATION PUBLISHED UNDER THE PATENT COOPERATION TREATY (PCT)

<p>(51) International Patent Classification ⁵ : A61M 11/00, 15/00, 16/10</p>	<p>A1</p>	<p>(11) International Publication Number: WO 94/09842 (43) International Publication Date: 11 May 1994 (11.05.94)</p>
<p>(21) International Application Number: PCT/US93/09781 (22) International Filing Date: 13 October 1993 (13.10.93) (30) Priority data: 07/967,638 28 October 1992 (28.10.92) US 08/058,875 6 May 1993 (06.05.93) US (71)(72) Applicant and Inventor: ROSEN, Charles, A. [US/US]; 139 Tuscaloosa Avenue, Atherton, CA 94027 (US). (74) Agents: BOZICEVIC, Karl et al.; Morrison & Foerster, 755 Page Mill Road, Palo Alto, CA 94304-1018 (US).</p>	<p>(81) Designated States: AT, AU, BB, BG, BR, BY, CA, CH, CZ, DE, DK, ES, FI, GB, HU, JP, KP, KR, KZ, LK, LU, LV, MG, MN, MW, NL, NO, NZ, PL, PT, RO, RU, SD, SE, SK, UA, UZ, VN, European patent (AT, BE, CH, DE, DK, ES, FR, GB, GR, IE, IT, LU, MC, NL, PT, SE), OAPI patent (BF, BJ, CF, CG, CI, CM, GA, GN, ML, MR, NE, SN, TD, TG).</p> <p>Published With international search report.</p>	

(54) Title: METHOD AND DEVICES FOR DELIVERING DRUGS BY INHALATION



(57) Abstract

A thin layer of a pharmaceutically active drug (14) is coated on the surface of an electrically conductive metal (13) which heats and converts the drug to a gaseous phase when a current is passed through the metal. The gaseous drug is inhaled by a patient allowing the drug to be absorbed into lung tissues and/or the circulatory system of the patient. The amount of drug in the thin layer and/or the amount of current passed through the electrically conductive metal (13) can be precisely regulated (4, 5) so that the dose of drug inhaled is tightly controlled. Converting the drug to a gaseous phase (8) reduces particle size to an absolute minimum (molecular) size thereby maximizing drug delivery and minimizing user compliance problems common to conventional metered dose inhalers. Methods of drug delivery as well as devices and drug dosage units used in the devices make it possible to quickly and efficiently administer a wide range of drugs locally to tissues of the respiratory tract and systemically to the circulatory system of a patient (10).

5 METHOD AND DEVICES FOR DELIVERING DRUGS BY INHALATIONCross References

10 This application is a continuation-in-part of
earlier filed pending U.S. application Serial No.
07/967,638, filed October 28, 1992, to which application
is claimed priority under 35 U.S.C. § 120 and which
application is incorporated herein by reference in its
entirety.

15

Field of the Invention

20 This invention relates generally to the field
of methods and devices for the administration of
pharmaceutically active drugs. More specifically, this
invention relates to methods of delivering drugs by
inhalation and to devices and drug dosage units used in
such methods.

Background of the Invention

25 Known devices for delivering aerosol medication
for inhalation by a patient include metered dose inhalers
that are manually operated and/or breath actuated.
Breath actuated inhalers typically contain a pressurized
propellant and provide a metered dose automatically when
30 the patient's inspiratory effort either moves a
mechanical lever or the detected flow rises above a
preset threshold, as detected by a hot wire anemometer.
See, for example, U.S. Patents 3,187,748; 3,565,070;
3,814,297; 3,826,413; 4,592,348; 4,648,393; 4,803,978;

35

-2-

4,896,832; and a product available from 3M Healthcare known as Aerosol Sheathed Actuator and Cap.

5 A major problem with manual metered dose inhalers is that the patient frequently actuates the device at the incorrect time during inspiratory flow to obtain the benefits of the intended drug therapy or during expiration. Thus, patients may inspire too little medication, or take a second dose and receive too much medication. The problem is, therefore, the inability to
10 administer precise dosages.

One problem with breath activated drug delivery is that the dose is triggered on crossing a fixed threshold inspiratory effort. Thus, an inspiration efforts may be sufficient to release a metered dose, but
15 the inspiratory flow following the release may not be sufficient to cause the aerosol medication to pass into the desired portion of the patient's airways. Another problem exists with patients whose inspiratory effort is not sufficient to rise above the threshold to trigger the
20 release valve at all. Yet another problem is that the particle size can vary greatly and larger particles cannot enter the smaller lung passages and therefore are not delivered to the same degree and/or rate as are smaller particles. Any of these problems can make it
25 difficult or impossible to monitor the delivery of a precise dosage of medication to a patient.

Attempts have been made to solve the patient inspiration synchronization problem. U.S. Patent 4,484,577 refers to using a bidirectional reed whistle to
30 indicate to the patient the maximum rate of inhalation for desired delivery of the drug and flow restrictor to prevent the patient from inhaling too rapidly. U.S. Patent 3,991,304 refers to using biofeedback techniques to train the patient to adopt a desired breathing
35 pattern. U.S. Patent 4,677,975 refers to using audible

-3-

signals and preselected time delays gated on the detection of inspiratory flow to indicate to the patient when to inspire and expire, and delivering inhalable material a selected time after the detected onset of flow. However, these devices also suffer from improper operation by patients who are not properly trained or do not conform their breathing to the instructed breathing pattern and whose inspiratory flow does not provide adequate delivery of the medication. Such problems make the delivery of predetermined dosages virtually impossible.

Studies in Byron (ed.), Respiratory Drug Delivery, CRC Press, Inc. (1990); Newman et al., Thorax, 1981, 36:52-55; Newman et al., Thorax, 1980, 35:234; Newman et al., Eur. J. Respir. Dis., 1981, 62:3-21; and Newman et al., Am. Rev. Respir. Dis., 1981, 124:317-320 indicate that during a single breath of an aerosol compound, only about ten percent of the total aerosol material presented is deposited into the lungs and that the location of deposition in the lung depends upon (1) breath parameters such as volume of inspiration, inspiratory flow rate, inspiratory pause prior to expiration, the lung volume at the time the bolus of medication is administered, and expiratory flow rate, (2) the size, shape and density of the aerosol particles (i.e., the medicinal compound, any carrier, and propellant), and (3) the physiological characteristics of the patient. Present devices and methods cannot eliminate these variables and as such cannot control dosage administration.

The publications authored by Newman et al. refer to measuring inspired air with a pneumotachograph to obtain a flow rate signal, which is integrated by a computer to determine lung capacity. A determined lung capacity, as a percent of vital capacity, is used as a

-4-

threshold to actuate a solenoid to depress the canister of a manually actuated metered dose inhaler on the inspiration of the predetermined lung volume.

5 A problem with existing metered dose inhalers, whether or not breath actuated, is that they are factory preset to deliver a fixed dose at a given particle size distribution. Such devices are not capable of reducing the dose to reflect improvement in the patient's condition, or selecting a maximum desired respirable
10 fraction of the aerosol mist that is suitable for a desired location of delivery of the medication in the particular patient.

Devices for controlling particle size of an aerosol are known. U.S. Patent 4,790,305 refers to
15 controlling the particle size of a metered dose of aerosol for delivery to the walls of small bronchi and bronchioles by filling a first chamber with medication and a second chamber with air such that all of the air is inhaled prior to the inhaling medication, and using flow control orifices to control the flow rate. U.S. Patent
20 4,926,852 refers to metering a dose of medication into a flow-through chamber that has orifices to limit the flow rate to control particle size. U.S. Patent 4,677,975 refers to a nebulizer device that uses baffles to remove
25 from any aerosol particles above a selected size. U.S. Patent 3,658,059 refers to a baffle that changes the size of an aperture in the passage of the suspension being inhaled to select the quantity and size of suspended particles delivered. A problem with these devices is
30 that they process the aerosol after it is generated and thus are inefficient and wasteful.

It is well known that pulmonary functions, such as forced expiratory volume in one second, forced vital capacity, and peak expiratory flow rate, can be measured
35 based on measured flow rates and used to (1) diagnose the

- 5 -

existence of medical conditions, (2) prescribe medication, and (3) ascertain the efficiency of a drug therapy program. See, for example, U.S. Patents 3,991,304 and 4,852,582 and the publications of Newman et al. discussed above. Heretofore, these tests have been performed using available spirometers. U.S. Patent 4,852,582 also refers to using a peak flow rate meter to measure changes in peak flow rate before and after administration of a bronchodilator. The results of such tests before and after administration of several different medications are used to evaluate the efficiency of the medications.

A problem with the foregoing pulmonary function test devices is that they are complicated for most patients to perform. Another problem is that the test data must be examined and interpreted by a trained medical practitioner to be meaningful. Another problem is that they do not provide adequately for altering the dosage of the medication administered in a single patient during the course of therapy, or from patient to patient, using the same delivery device for generating an aerosol of the same or different medications.

Attempts have been made to solve many of the above-referred-to problems. However, inconsistent user compliance combined with undesirably large particle size continues to cause problems with obtaining precise dosing.

Summary of the Invention

The delivery methodology and, in particular, the delivery of drugs by inhalation via the interpulmonary route is obtained by (1) heating a drug, preferably in the form of a thin solid layer of drug to a temperature such that at least a portion of the drug is converted to a gaseous state, and (2) inhaling a known

-6-

dosage amount of the gaseous drug into the lungs. The drug is preferably heated by an electrically heating means which can be precisely controlled and the amount of drug heated for delivery by a single administration is preferably 25 milligrams or less.

The drug may have an immediate topical/local effect on lung tissues and/or enter the circulatory system of the patient. When the drug is controllably heated and converted to a gaseous state, it is reduced to its smallest possible particle size, i.e., molecular size, thereby maximizing the amount of lung surface area which can come into contact with the gaseous drug. Further, dosaging problems and drug waste caused by large particle sizes inherent within aerosolized systems are minimized by the very small and uniform size of the gaseous drug.

In general, the method involves coating a thin layer of drug onto a surface where the drug can be heated. The drug may be coated on an article near a heating element or coated on the heating element in the form of an electrically conductive surface which can be heated by applying electrical energy. The amount of drug coated on the electrically conductive surface as well as the amount of energy applied can be precisely controlled in order to provide for the generation of a precise dose. The precise dose generated is administered to the patient without the problems inherent to conventional metered dose inhalers in that the dosage generated is molecular in size (completely uniform and small) and can readily be inhaled into the lungs and will thereafter be absorbed into the blood.

In order to carry out the drug delivery methodology of the invention, interpulmonary drug delivery devices and drug delivery units used in those devices are provided. The drug delivery device includes

-7-

a heating element, a drug vaporization chamber, a mouthpiece in connection with the chamber and a predetermined dose of a pharmaceutically active drug which is positioned in the chamber in such a manner that when the heating element is activated, a predetermined amount of the drug dose undergoes a phase transition to a gaseous state inside the chamber. The drug delivery unit is used in connection with the drug delivery device may be comprised of an electrically conductive material and a layer of pharmaceutically active drug coated on the conductive material or in close proximity with the conductive material such that when the conductive material is heated the drug is converted to a gaseous state. The drug may be maintained in the unit under a vacuum or reduced pressure and/or in an inert gas atmosphere. A plurality of drug delivery units can be provided with the drug delivery device so that the patient can use the device to delivery multiple doses over time. By adjusting the amount of drug heated and/or the amount of energy provided, the predetermined dosage of gaseous drug created can be controlled and varied in accordance with patient needs. The device may include an internal timer integrated with the heating means and/or dosage unit supply means so that the amount of the dosage created is varied with the time of day. For example, the largest dosage might be delivery in the morning and the amount decreased over the day. Other adjustments can be made to best match the chronobiology of the patient.

In accordance with one general embodiment individual drug dosage units are coated with a drug by the manufacturer and the drug dosage units are loaded into the drug delivery device by the user which device heats the drug dosage unit until the drug is vaporized and thereafter inhaled by the user. The drug dosage unit is then completely exhausted and discarded. However, in

- 8 -

accordance with a second embodiment, the drug delivery device is loaded with a container which contains multiple doses of a drug in liquid and preferably pressurized form. For example, the container could be a standard
5 metered dose inhaler container containing the drug dispersed in a low boiling point propellant. The drug is then dispensed from the container onto the surface of a heating element. Any propellant within the container immediately "flashes" or evaporates leaving the drug
10 present in a thin layer on the heating element. Thereafter, the heating element is activated and the drug is vaporized and inhaled by the user.

An object of this invention is to provide devices, dosage units, systems, and methods for
15 delivering drugs to a patient.

Another object of this invention is to provide devices, dosage units, systems, and methods for delivering drugs wherein the particle size is highly uniform and is reduced to an absolute minimum, i.e., a
20 molecular level.

Yet another object of the invention is to provide drug delivery dosage units which can be used to provide precise, predetermined dosage amounts of drug to a patient by inhalation, i.e., via the interpulmonary
25 route.

Still another object of the invention is to provide a drug delivery device which can be loaded with a container charged with multiple doses of a drug which can be dispersed onto a surface, heated, vaporized and
30 thereafter delivered to the patient.

An advantage of the present invention is that by reducing the drug particle size to an absolute minimum molecular size it is possible to maximize the amount of lung surface area which the drug can enter through.
35

- 9 -

Another advantage of the present invention is that due to the uniform and small molecular size of the gaseous drug, errors in patient administration are substantially eliminated in that large and variable sized aerosolized particles of drug will not be substantially wasted by misfires against the patient's mouth, tongue and/or throat.

Another advantage of the invention is that drugs can be applied in uniform, predetermined amounts on the surface of lung tissues.

Still another advantage of the invention is that the amount of energy applied and/or the amount of drug in the dosage unit can be varied over time so that different amounts of gaseous drug can be generated and delivered to the patient in a manner complying with the needs of the patient.

Yet another advantage of the present invention is that it can be readily adapted for use with conventional metered dose inhaler containers in a manner which can dramatically improve the efficiency and accuracy of drug delivery to a patient.

A feature of the present invention is that the thin layer of drug on the dosage unit can be readily and easily converted to a gaseous phase with a small amount of energy.

Another feature of the present invention is that the drug can be converted to a gas from its thin layer at a relatively low temperature compared to its decomposition temperature, e.g. 10C° or more below its decomposition temperature.

Another feature of the present invention is that the drug devices and drug dosage units are small in size and convenient to use.

Yet another feature is that the gaseous drug is molecular and thus completely uniform in size.

-10-

These and other objects, advantages and features of the present invention will become apparent to those persons skilled in the art upon reading the details of the drug delivery methodology, dosage devices and dosage units as fully set forth below, reference being
5 made to the accompanying drawings forming a part hereof.

Brief Description of the Drawings

Figure 1 is a plan view of a preferred
10 embodiment of a drug delivery device of the present invention;

Figure 2 is a plan view of a drug delivery unit of the present invention;

Figure 3 is a cross-sectional plan view of an
15 inductance coil heating means;

Figure 4 is a plain view of another embodiment of a drug delivery device of the present invention, showing a pressurized drug formulation canister;

Figure 5 is a perspective view of another
20 embodiment of the invention;

Figure 6 is a cross-sectional side view of the embodiment shown in Figure 5;

Figure 7 is a cross-sectional rear view of the embodiment shown in Figure 5;

Figure 8 is a cross-sectional top view of the
25 embodiment shown in Figure 5;

Figure 9 is a perspective view of another embodiment of a drug delivery unit.

Detailed Description of Preferred Embodiments

Before the present drug delivery methodology, devices and drug delivery units, as well as means for using and making such are described, it is to be understood that this invention is not limited to the
35 particular methods, devices and units described as such

-11-

may, of course, vary. It is also to be understood that the terminology used herein is for the purpose of describing particular embodiments only, and is not intended to be limiting since the scope of the present invention will be limited only by the patented claims.

It must be noted that as used in this disclosure and the appended claims, the singular forms "a," "and," and "the" include plural referents unless the context clearly dictates otherwise. Thus, for example, reference to "a drug" includes mixtures of drugs, reference to "an electrically conductive material" includes alloys of and several types of such materials, and reference to "the method of drug delivery" includes one or more different methodologies of the type known to those skilled in the art and which will become apparent to those skilled in the art upon reading this disclosure and so forth.

Definitions

Unless defined otherwise, all technical and scientific terms used herein have the same meaning as commonly understood by one of ordinary skill in the art to which this invention belongs. Although methods and materials similar or equivalent to those described herein can be used in the practice or testing of the present invention, the preferred methods and materials are now described. All publications mentioned herein are incorporated herein by reference in their entirety and specifically with respect to disclosing and describing the particular technology in connection with which the publication is cited.

The terms "drug" and "pharmaceutically active drug" are used interchangeably herein and are intended to encompass compounds which when administered to a living being induce a detectible biological response. Preferred

-12-

drugs include those which are approved for sale by the Food and Drug Administration as being safe and effective and further include compounds approved for sale in countries other than the United States. The terminology is intended to encompass those compounds which when administered to a patient induce a biological effect which is beneficial to the treatment of the patient and which benefit outweighs any detrimental effect to the patient. Accordingly, the terms "drug" and "pharmaceutically active drug" specifically exclude illegal compounds which have a significant effect on the neurological system without a corresponding medical benefit.

The term "energy" is intended to encompass any form of energy capable of heating a drug to a temperature such that an amount of the drug is converted to a gaseous phase, but specifically excludes the use of open flames and/or ignited materials which must burn (i.e. undergo combustion) in order to generate heat. Preferred forms of energy include those which are generated by the administration of electrical energy in a controlled fashion and include lasers, metal coils and strips and induction coils. Particularly preferred energy sources are precisely controlled electrical heating means whereby the amount of heat generated is precisely controlled by the amount of electrical energy applied to an electrically conductive material as such a metal.

The term "predetermined amount" refers to the amount of drug coated on a drug dosage unit of the invention and/or the amount of gaseous drug vaporized from the dosage unit upon the application of energy which amount is known to an individual. The predetermined amount is preferably an amount which is effective in the treatment of a disease and/or symptom of a disease of the individual to which the drug is administered. The

-13-

predetermined amount is preferably an amount which is 25 milligrams or less and more preferably in the range of about 10 micrograms to 10 milligrams. The term "predetermined amount" is also intended to mean an amount of drug dispensed from a conventional metered dose inhaler container and/or other drug container upon the release of the valve. In general, the term "predetermined amount" refers to a known amount which amount is known to the manufacturer, caregiver and preferably the patient administering the drug. Conventional metered dose inhaler devices are designed such that when the valve is released, a predetermined or known amount is dispersed from the container and the same amount will be dispersed each time the valve is released in order to provide for repeatability in dosing.

The term "gaseous drug" is intended to mean a drug by itself or in combination with an excipient material in a gaseous phase in that the drug has undergone a phase transition from a solid and/or liquid state to the gas phase. The "gaseous phase" of the drug encompasses a phase wherein the drug by itself or with excipient materials is reduced to its smallest possible size (i.e. molecular size) without being decomposed. Accordingly, the term is specifically intended to exclude aerosolized and/or nebulized forms of drugs which create particles which include large numbers of molecules in each particle.

General Description

Although a number of different embodiments to the methodology, devices and drug dosage units of the present invention can be contemplated, the present invention involves three basic aspects which include (1) the method of delivering a gaseous form of predetermined amount of a drug by inhalation, (2) devices

-14-

used in the method, and (3) drug dosage units used in the devices.

5 The invention can be carried out by coating a thin layer of pharmaceutically active drug on the surface of an electrically conductive material (e.g., metal) which can be heated by passing a current through the metal and thereby causing the drug to undergo a phase transition to a gaseous phase. The drug continues in its gaseous state for some time within the vapor chamber of the device and can be inhaled from there into the lungs of a patient. The gaseous drug will be in molecular-sized particles, each of which will be completely uniform in size and shape and in the smallest possible particle size, i.e., molecular size. Accordingly, the drug can be easily inhaled into the lungs and will utilize the maximum lung surface area which surface, when contacted, allows the drug to enter the lung tissue and/or enter into the circulatory system of the patient.

15 The pharmaceutically active drug need not be coated directly onto the electrically conductive metal surface in order to produce a drug dosage unit of the present invention. The electrically conductive metal surface may be coated with an inert material and the drug coated on the surface of the inert material. This is done in order to avoid any interaction between the metal and the drug. In yet another embodiment, the drug may be coated onto the surface of an inert material which material is not in direct contact with the electrically conductive material, but is positioned in sufficient proximity to the electrically conductive material so that when the electrically conductive material is heated, the drug is heated to a sufficient temperature to cause the drug to undergo a phase transition to produce gaseous drug. In another embodiment, the drug is converted to the gaseous phase by directing the energy of a laser

-15-

which is preferably a solid state laser at a particle of drug or a drug coating position on a substrate. In another embodiment, the drug dosage unit having the drug coated on an electrically conductive substrate is placed
5 within an inductance coil which is caused to generate heat energy by the application of high frequency radio oscillations. Although the drug can be converted to a gaseous phase by the application of a number of different forms of energy, the present invention does not include
10 the use of flames and specifically the use of open flames in order to create the gaseous drug. The use of flames are excluded in that flames generally provide an uncontrolled amount of energy which has two undesirable effects. Firstly, the flames may, and often do, cause
15 the drug to decompose. Secondly, the flame cannot generally be controlled in such a manner so as to produce a predetermined amount of gaseous drug, but rather will produce a random, uncontrolled amount of gaseous drug. Uncontrolled amounts of gaseous drug result in
20 uncontrolled dosing which is contrary to the essence of the present invention.

Each of the drug dosage units described above refer to the coating of the drug on some surface. The drug may be directly coated on a heating element or
25 coated on some other element which is caused to be heated by one of several different means. The drug may be coated on the surface at two basically different points in time relative to drug delivery. In accordance with one general embodiment, the drug is coated on the surface
30 during manufacture of the drug dosage unit. In accordance with this general embodiment, a predetermined amount of drug is coated onto a surface such as a heating element and thereafter the coated surface is loaded into a delivery device, heated, vaporized and delivered to a
35 patient. After delivery, the drug dosage unit is then

-16-

discarded. In accordance with another general embodiment, the drug is coated onto the surface of the drug dosage unit by the patient or caregiver prior to use. In accordance with this embodiment, a container
5 which includes multiple doses such as standard metered dose inhaler container is loaded into the drug dispensing device. By releasing the valve of the container, a predetermined amount of drug is forced from the container onto a surface where it is deposited. The drug deposited
10 on the surface is then heated, vaporized and inhaled by the patient. In accordance with this embodiment, the surface having the drug dispersed thereon can be repeatedly used in that it is repeatedly coated with more drug which is dispersed from the container which holds
15 multiple doses.

A device of the present invention which can carry out a method of the invention must include some heating element and position the drug to be heated in sufficient proximity to that heating element so that the
20 drug can be heated to a gaseous state. A variety of different configurations for obtaining such will, no doubt, occur to those skilled in the art upon reading this disclosure. In connection with producing preferred embodiments, it is pointed out that it is desirable to
25 coat the drug in as thin a layer as possible. Thinner layers can be heated more uniformly throughout their thickness as compared to thicker layers and will, therefore, more efficiently utilize energy applied as compared to thicker layers. Another factor which should
30 be considered is that the electrically conductive element, heating element, or other material which the drug might be coated on should be comprised of a material such that it has substantially no vapor pressure at temperatures which will be utilized. This is done in
35

-17-

order to avoid any intermixing of gaseous forms of such material with the drug being delivered to the patient.

5 Some of the drugs used in connection with the present invention are liquid at room temperature. When such drugs are utilized, it may be desirable to mix the drug with an inert carrier such as aluminum oxide in order to effectively coat the drug on the surface of a substrate prior to converting the drug to a gaseous phase. The inert material should be a material such that
10 when subjected to temperatures in the range of 300°C to 400°C the material does not generate any detectible vapor pressure as such would contaminate the drug being administered.

The amount of drug coated on the thin layer of
15 electrically conductive material, as well as the voltage, power, and time period for the current passed through the electrically conductive material, can be regulated in order to control the dose of gaseous drug created and thereby closely control the dose administered to the
20 patient. Since (1) the amount of gaseous drug can be closely controlled, (2) the particle size is minimized, and (3) particle size and shape is uniform, the methodology minimizes user compliance problems common with conventional metered dose inhalers. When all or
25 substantially all of the drug on the electrically conductive material has been converted to a gaseous state and the patient requires additional dosing, another drug dosage unit can be inserted into the drug delivery device and the procedure repeated. Alternatively, it is
30 possible to disperse additional drug from a drug container onto the surface which can allow heating of the coated drug. This embodiment and procedure does not require replacement of the drug dosage unit, only a recoating of the drug dosage unit or the walls of the
35 heating chamber with more drug when the coated drug has

-18-

been vaporized. Eventually, drug contained within the drug container will be exhausted and a new container must be included within the drug dispensing device.

5 Since the system makes it possible to directly administer a drug to the circulatory system of a patient, a wide range of drugs can be administered in this manner. The drugs will not be broken down by chemicals within the GI tract or metabolized in the liver by first-pass liver metabolism, a problem common to oral drug delivery
10 methodology. Provided the drug can undergo a phase transition to a gaseous state without altering the functionality of the drug and provided that sufficient energy can be applied to produce a gaseous form of the drug, it may be administered using the methodologies,
15 devices and dosage units of the present invention.

By reviewing a copy of the Physicians' Desk Reference and/or the Merck Index (both incorporated herein by reference — latest editions), it can be seen that most pharmaceutically active drugs are organic
20 compounds. Characteristics of many organic compounds such as their melting point, boiling point and vapor pressure at given temperatures are given in publication such as the Handbook of Chemistry and Physics and/or can be calculated by those skilled in the art. Examination
25 of these compounds reveals that many of the compounds have a relatively high vapor pressure at a relatively low temperature. Due to this characteristic, these compounds require the application of a relatively small amount of energy in order to generate vaporized drug. More
30 specifically, when the drugs are coated onto a substrate, a relatively small amount of heating causes the drugs, which are generally crystalline substances, to create a partial gaseous vapor pressure, i.e., convert directly from a solid crystalline or liquid form into a gaseous
35 phase without boiling.

-19-

Most solid substances can be heated to a melting point at which point the substance will undergo a phase transition to a liquid state and can be heated in the liquid state to a boiling point at which point the liquid undergoes a phase transition to a gaseous state. However, some solid substances undergo a phase transition from the solid to a gaseous state, i.e., they sublime. Both types of compounds can be used in connection with the present invention. If the compound does not sublime, it is generally necessary to heat the compound to a temperature somewhat above its melting point, although generally not necessary to heat the compound to its boiling point. After being heated to its melting point, the compound will generate a partial gaseous vapor pressure. That vapor pressure will increase as the temperature is increased until the vapor pressure reaches atmospheric pressure at the boiling point. However, at temperatures well below the boiling point, sufficient vapor pressure is generated so as to provide a sufficient amount of gaseous drug vapors for delivery to the patient.

Those skilled in the art can readily determine the vapor pressure at any given temperature and thereby determine the amount of gaseous drug which will be created. Provided sufficient energy can be applied to the drug material to generate some vapor pressure, the drug can be used in connection with the present invention. However, the most preferred drugs are drugs which sublime, i.e., convert directly from a solid to a gaseous phase. Other preferred drug materials include those which have relatively high vapor pressures, e.g., vapor pressures of 0.25 atmospheres, preferably 0.5 atmospheres or more at a temperature of 10 to 20 centigrade degrees above or below the melting point of the drug.

-20-

It is well known that the vapor pressure of any given material is affected by both the temperature and surrounding pressure. Accordingly, in some instances, it is desirable not only to increase the temperature by the heating means but to decrease the surrounding pressure. This can be done by the inclusion of valves and a pump in connection with the vaporization chamber of the drug delivery device. For example, a piston means can be included within the chamber. When the piston is withdrawn from the chamber, the pressure within the chamber is reduced. Thereafter, the piston can be locked into the place with the reduced pressure being utilized to increase the amount of drug vapor which will be created at a given temperature. Electrically or manually operated pumps can be connected by tubes to the vaporization chamber in order to reduce the pressure within the chamber.

The above characteristics relate to the physical characteristics of drugs which might be used in connection with the invention. From a pharmacological standpoint, any compounds might be used which compounds are generally delivered to a patient for treatment. However, preferred compounds are those compounds which have a topical and/or local effect on the lungs such as those conventionally administered such as steroids and bronchodilators. Other compounds which might locally treat the lung include antibiotics to treat infections such as pneumonia and anticancer drugs to treat lung cancer. In addition to providing drugs which locally treat lung tissues, the invention can be used to systemically administer drugs to treat any diseases. Preferred drugs, however, include those which operate on the heart and/or nervous system in that the drug will be delivered from the lung to the heart to the brain within a matter of seconds. Accordingly, drugs used to treat

-21-

heart diseases as well as antidepressants and other psychoactive drugs used to treat diseases of the central nervous system are considered preferred candidates in connection with the present invention. In general, it is not the pharmacokinetics but the physical properties of the drug which determine which drugs are preferably used in connection with the present invention. Drugs which produce relatively high vapor pressures at temperatures above 50°C and preferably less than 350°C are preferred drugs. Thus, if the drug generates a vapor pressure of 0.25 atmospheres, more preferably 0.5 atmospheres, at a temperature in the range of 50°C to 350°C, the drug is a preferred candidate for use in connection with the present invention. In connection therewith, it is pointed out that physical characteristics of a drug such as its melting point, boiling point and vapor pressure will vary when the forms of the drug are varied. For example, salts and/or base forms of a drug will have a different melting point than the free acid of the drug and such will be readily understood by those skilled in the art. Further, the physical characteristics of the drug can be changed to a certain extent by imbedding the drug in another material, i.e., the drug need not be used in pure form. In certain circumstances, it is possible to improve vapor pressure characteristics by intermixing the drug and/or embedding particles of the drug in another material.

Those skilled in the art will recognize that certain drugs do decompose when heated to temperatures sufficient to create enough vapor pressure so that the drug could be delivered by inhalation. For example, with respect to narcotics, drugs such as morphine and hydromorphone decompose rapidly upon melting. However, other narcotic drugs such as fentanyl, sufentanil and meperidine show only trace amounts of decomposition upon

-22-

melting and could, therefore, be readily used in connection with the present invention. Those skilled in the art can readily test drugs in order to determine their degree of decomposition using procedures known to those skilled in the art. For example, the procedures and information disclosed by Roy et al., Pharmaceutical Research, Vol. 5, No. 9, 1988 "Solubility and Related Physicochemical Properties of Narcotic Analgesics" which is incorporated herein by reference discloses such procedures. For purposes of the present invention, the term "decomposition" is intended to mean that the drug is somehow changed to the extent that it will no longer provide for the desired pharmaceutical effect when delivered to a patient. Accordingly, some drugs may decompose to a small extent but be sufficiently potent such that when the drug is vaporized the vapor will include sufficient numbers of nondecomposed molecules so as to provide the desired pharmaceutical effect. Such effects can be readily determined by those skilled in the art by carrying out standard testing procedures involving heating the drugs and thereafter testing the resulting heated drugs for changes.

The present invention can be used for the delivery of drugs to any living organisms provided those organisms present a membrane for the exchange of gases. However, the invention is particularly designed for the delivery of drugs to humans by inhalation. The present invention operates by having a patient inhale the gaseous drug through the nose or mouth into the trachea. After entering the trachea, the gaseous drug will enter the bronchial tubes and eventually enter into the thousands of small sacs referred to as alveoli. During normal respiration, membranes within the lung allow CO₂ to be expelled and oxygen to enter. Gaseous drug can and will enter through the same membranes. When treating certain

-23-

lung diseases, the drug need only enter the membrane and have a topical or local effect on the lung tissues such as by acting as a bronchodilator. However, sufficient amounts of the drug can be delivered so that the drug will enter the circulatory system of the patient. From the lungs the blood flow travels directly to the heart and from there to the brain. Accordingly, within a matter of seconds of inhaling the gaseous drug, the drug has an effect within the brain of the patient. In view of such, it can be seen that the present invention is particularly applicable with respect to the delivery of drugs which treat the lungs, heart or central nervous system, e.g., the administration of bronchodilators and antidepressants can have an almost immediate effect on the patient.

During normal respiration of a human, much of the air entering the lungs is known as "dead air" in that it does not enter into the exchange of gases occurring within the lung. Only about a pint of the air inhaled during one inspiration will enter the lungs, i.e., pass through lung membranes into the circulatory system. In view of such, the importance of obtaining small particle sizes which allow the drug to enter deeply into the lung becomes apparent. When using conventional metered inhalers (directly, i.e., without the delivery device of the present invention), the large and irregular particle sizes cannot be dispersed uniformly throughout the thousands of alveoli, thus leaving much of the lung tissue untreated and/or not utilizing much of the tissue in order to delivery drug to the circulatory system of the patient. When the surface area of the lung is efficiently utilized, it is an extremely efficient means of delivering a compound to the circulatory system and/or lung tissue of the patient. Further, by deep breathing, the efficiency of the system can be substantially

-24-

increased. For example, during strenuous exercise, the amount of oxygen used by the body increases by 10 or more times that normally used. The increase in carbon dioxide within the blood results in a gasping for breath and/or
5 feeling of fatigue, aching muscles and other signs of lack of oxygen. Although such symptoms appear to be caused by an inadequacy of the respiratory system, they are, in fact, caused by the inadequate amount of blood pumped by the heart to the lungs and not inefficiencies
10 of the respiratory system.

One of the more important and unique aspects of the present invention is the ability to provide for interpulmonary drug delivery while delivering a tightly controlled and predetermined amount of gaseous drug. The
15 control of the predetermined amount of drug delivered is governed by a plurality of factors including (1) the uniformity of the particle size; (2) the smallness of the particle size; (3) the amount and thickness of the layer of drug coated on the substrate to be heated; (4) the
20 current or energy applied to heat the drug; (5) the amount of time the current is applied; (6) the distance between the drug and the heating element; and (7) the atmosphere (or lack thereof) surrounding the coated drug being heated.

25 In connection with the methodology of the present invention, the small particle size and uniformity of the size will of course remain constant with a particular drug. However, the amount of energy, e.g., current, the time the energy, e.g., current is applied,
30 the distance of the drug from the heating element and the atmosphere surrounding the drug can be varied. The drug dosage units of the invention can be designed so that all or substantially all of the drug contained on the substrate to be heated will be vaporized. Alternatively,
35 the dosage units can be designed so that they include

-25-

multiple doses and the amount of the dose to be delivered is determined by the amount and time the energy is applied, e.g., the current times the voltage times the time applied, and thus, the amount of heating obtained.

5 All these factors will effect the amount of gaseous drug created in that the gaseous drug will provide molecular-size particles which are small and uniform in size and the amount of drug actually delivered can be closely controlled.

10 Problems with conventional metered dose inhalers relate, in large part, to the fact that particles generated are not uniform in size, and more importantly, the particles are relatively large in size. When a conventional metered dose inhaler is actuated or
15 fired, most of the drug being released from the device is not delivered to the patient if the nozzle of the device is misdirected or if the patient is not firing the device at the correct time during the respiration cycle. For example, if the metered dose inhaler is fired and the
20 dosage released is directed at the side of the mouth, tongue, or roof of the mouth, the drug will contact that area, stick, and not enter into the lungs. If the particle size is relatively large, the particles which are inhaled may precipitate out on the passageways to the
25 lungs and will not enter into the smaller channel openings within the lungs. If the patient fires the metered dose inhaler while exhaling, much of the dose can be exhaled from the mouth and not delivered from the patient. When using the drug-delivery device of the
30 present invention, the device can be fired or actuated at essentially any time. After actuation, the drug is heated to produce the vaporized drug which will remain in the vaporization chamber until it is sucked out by the patient inhaling the vaporized drug. Since the drug
35 particle sizes are so small and so uniform in size, the

-26-

inhalation can be complete and the particles will not precipitate out on the mouth and throat. Due to the small particle size, the particles will enter the smallest channels within the lungs and provide a wide area for entry into the circulatory system of the patient.

Although conventional metered dose inhalers have a number of disadvantages, as indicated above, it is possible to use a conventional metered dose inhaler container in connection with one embodiment of the present invention and thereby overcome such disadvantages. More specifically, the container of a metered dose inhaler will disperse a predetermined amount of drug from the container when the container's valve is released. That predetermined amount of drug can be directed at a surface and will cause the drug to be deposited on the surface. Propellant (which is generally a low-boiling-point propellant, such a hydrocarbon or fluorocarbon) will immediately "flash" or evaporate, leaving only the drug coated on the intended surface. The surface can be a heating element or a surface positioned in close proximity to a heating element. When heat is applied to the drug it is vaporized in the same manner as indicated above to create drug vapor, which includes small, molecular size particles uniform in size, which can be readily inhaled by the patient into the smallest channels of the lungs and thereby provide for improved efficiency with respect to the delivery of the drug from the conventional metered dose inhaler container.

In order to maximize the amount of vapor generated with a minimum amount of energy, it is desirable to produce the layer of drug in the smallest possible thickness. The layer of drug can be created by a variety of different techniques such as

-27-

electrophoresis, spraying, precipitation from solution, and other coating methodologies generally known to those skilled in the art. The methodology should be chosen based on factors such as the type of drug and substrate being used and the methodology which will be most convenient and economical. With respect to the substrate, it is pointed out that a variety of materials can be utilized, provided they are capable of being heated when electrical energy is applied. Suitable materials would include well-known electrical conductors such as copper, silver, gold, and alloys thereof, which may be present in pure metallic form or coated with a substrate material on which the drug is then coated. In addition to metals, many inorganic materials can be used as the substrate material. However, the inorganic materials should be chosen so that the inorganic material itself has an extremely small and essentially nondetectable vapor pressure at temperatures of up to 350°C — the same is true with respect to any material used to coat the electrically conductive material. This characteristic is mentioned in that it would not be desirable to generate vapors of the electrically conductive material which would be delivered to the patient along with the drug.

The coated layer of drug can also be created by spraying drug released from a conventional metered dose inhaler container onto a support surface. Although this embodiment of the invention is particularly convenient, in that it makes it possible to use a drug-dispensing device of the invention with a currently approved drug formulation, it is not desirable in that it does not provide for the thinnest possible layer of drug on the surface of the support.

35

-28-

Each of the three basic aspects of the invention will now be described with reference to Figures 1, 2 and 3.

5 The Drug Delivery Device

Figure 1 is a plain schematic view of the drug delivery device (1) of the present invention. The device (1) is shown schematically and in a particular embodiment to which the present invention is not limited. However, basic elements of the drug delivery device (1) are shown. The device includes a power source (2) which may be a conventional battery or plurality of batteries. The power source (2) is connected by an electrical wire (3) to a capacitor (4) and a switch (5). When the switch (5) is actuated, the stored energy of the charged capacitor is delivered via the connection (6) to the drug delivery unit (7). A variety of different electrical components and circuitry (not shown) can be used in connection with the device in order to obtain desired results such as increasing the amount of voltage and thus heat energy applied to the drug. Further, it is possible to include an electrical timing device (not shown) which after actuation with the switch (5) allows the power to be supplied from the source (2) for a predetermined period of time.

In its simplest form, a power source (2), such as a battery is directly connected to a heating element in or in the vicinity of the chamber (8). However, because batteries do not generate large amounts of voltage, it is preferable to have the power source connected to an intermediate device, such as the capacitor (4). Although additional electronic components and circuitry are not shown, it is generally preferable to include additional components which aid in increasing the voltage of the power source and bringing the charge

-29-

of the capacitor to a full charge more quickly. Such electronic components and circuitry are generally known to those skilled in the art and include the type such as the components used in connection with the electronic
5 flashes on photographic equipment.

The drug delivery unit (7) is present within a drug vaporization chamber (8). However, the delivery unit (7) may be designed in such a manner so that the drug is vaporized within the drug-delivery unit and thus
10 the drug-delivery unit provides the drug vaporization chamber. In the embodiment shown in figure 1, the chamber (8) is connected via a passageway (9) to a mouthpiece (10).

The device (1) may be designed so that the
15 chamber (8) is separated from the passage (9) by a valve means (11) which can be opened or closed by any suitable mechanical means and may be connected to the switch means (5) so that the valve (11) is opened when the switch means (5) is actuated or opened at a predetermined time
20 after the switch means (5) is actuated. The device (1) may also be designed to include a plurality of additional drug delivery dosage units, shown as (7'), (7''), and (7'''). These additional dosage units can be positioned within the device so that they can be easily removed and
25 replaced within the chamber (8) or the device (1) can be designed such that a new unit such as the unit (7''') will automatically take its place in the chamber (8) after the dosage unit (7) is used. This mechanism can be designed in a manner similar to that of a semiautomatic
30 gun which reloads a chamber and ejects cartridges once the bullet has been fired. Accordingly, the dosage unit (7) within the chamber can be designed to be ejected from the chamber (8) when all the drug has been vaporized. Such a design is desirable so as to avoid a situation
35 whereby a patient might actuate the device (with an empty

-30-

unit in the chamber) and believe drug was being delivered when in reality no drug was present to be vaporized.

The device (1) may be designed with a variety of different optional features in order to emphasize the desirable characteristics of the present invention such as the ability to precisely produce predetermined amounts of gaseous drug with a small amount of energy. For example, it is possible to design the device (1) to include a means for reducing the pressure within the vaporization chamber (8). Such a means could include a suitable pump (not shown) connected to the vaporization chamber (8) by any suitable means. The pump could be manually or electrically operated so as to suck air out of the vaporization chamber and provide a vacuum or reduced pressure within the chamber (8). Alternatively, a piston (not shown) could be included within the passage way (9) in such a manner that the piston tightly fits to the internal circumference of the passage way (9). When the piston is withdrawn away from the chamber (8) towards the mouthpiece (10), the pressure within the vaporization chamber (8) is reduced. Thereafter, the heating element could be actuated and the pressure allowed to return to normal atmospheric pressure due to the creation of the gaseous drug within the vaporization chamber (8).

In accordance with still another modification, the drug delivery device (1) can be combined with a laser such as a solid state laser (not shown). The focal point of the laser can be directed at an area of the vaporization chamber (8) where the drug will be placed. If a laser is to be used, the drug may be present in a thin layer but can be present in any shape or form provided that the laser can be focused on the drug in a manner so as to create a predetermined amount of gaseous drug when the laser is actuated for a given period of time.

-31-

The Drug Dosage Unit

Referring now to Figure 2, a particular embodiment of a drug-dosage unit (20) is shown. The dosage unit (20) is in the form of a glass cylinder (21) which has electrically conductive metal ends (22) and (22'). The cylinder (21) may be an open-ended tube or a closed cylinder which is opened in the chamber (8) such as by removing or puncturing one or both of the ends 22 and 22', preferably after the vapor has been generated by heating. The metal ends are connected to each other by a metal substrate which has the drug coated thereon. The interior of the unit (24) may be held under vacuum or may be subjected to a vacuum and then filled with an inert gas if the ends are closed and have at least one end opened after the unit (20) is placed in the chamber (8) shown in Figure 1. This is done in order to avoid the possibility of any of the drug being oxidized when the drug is heated. Oxidation of the drug would be likely to destroy the activity of the drug. Other drug-delivery dosage units can be readily designed with an understanding of the present invention in mind. What is necessary is that the dosage unit provide some substrate upon which the drug can be coated in a thin layer. The substrate need not itself be electrically conductive, but must allow the drug to be heated so that the drug can be vaporized off of the substrate into the drug vaporization chamber. Accordingly, it is possible to have the drug coated on the surface of the glass (21) shown at Figure 2 and heat the metal (23) to a sufficient temperature so as to vaporize the drug on the glass (21). The amount of heat applied will vary with the drug and must be kept below the decomposition temperature of the drug, e.g. 5 to 10C° below the decomposition temperature. Each of the various drug delivery dosage units (20) are considered to be important aspects of the present invention. A device

- 32 -

(1) as shown within Figure 1 can be reused a multiplicity of times, however, the dosage units (20) of Figure 2 may be expended after a single use. At best, such dosage units would be expended after a few doses had been
5 delivered to the patient.

Figure 3 is a cross-sectional plan view of another embodiment of the vaporization chamber (8) of the invention. The chamber (8) is comprised of a wall (12) which wall has an induction coil (13). In accordance
10 with this embodiment, a dosage unit (14) can be inserted within the chamber and high frequency radio oscillation energy can be applied so that a drug on the unit (14) is converted to the vapor phase. This drug unit has a thin
15 film of drug deposited on an electrically conductive layer which is heated inductively by the high frequency radio energy. This embodiment is somewhat more complex than the use of a conventional heating element. However, the embodiment of figure 3 is desirable in that the coil
20 (13) need not directly have an electrical connection with any portion of the dosage unit (14). The elimination of electrical contacts makes the device more durable and reduces error in calculations such as the calculation of the amount of energy generated which calculations might be effected by incomplete electrical connections.

25 Figure 4 shows another embodiment of a drug delivery device (25) which is similar to the device 1 shown in Figure 1. The device (25), as shown within Figure 4, is basically different from the device (1), shown in Figure 1, in two respects. Firstly, the device
30 (25) includes the induction coil (13), as shown within Figure 3. Secondly, the device (25) does not include the drug delivery units (7), as shown within Figure 1. Instead, the device (25) includes a canister (26) which includes multiple doses of drug. The canister (26) is
35 preferably a pressurized canister used in connection with

-33-

conventional metered dose inhalers. Accordingly, the canister (26) will include a liquefied drug formulation dispersed throughout a low-boiling-point propellant, such as a hydrocarbon or fluorocarbon. Since fluorocarbon compounds are not desirable environmentally, it is possible to modify the canister (26) to include other propellants or to force drug from the container by other mechanical pressurizing means (not shown). The container (26) includes a valve (27) and a nozzle (28). A mechanical leverage means (29) is connected between the switch (5) and the canister (26). When the switch (5) is actuated the leverage means (29) pushes the canister (26) in the direction of the opening or passageway (30), which leads to the chamber (8). The valve (27) is designed such that when the nozzle (28) is forced toward the passageway (30), the valve (27) releases a predetermined amount of drug. The drug will flow directly into the passageway (30) and thereafter into the chamber (8). At this point, the valve (11) is closed. Within the chamber, the drug will deposit on the inner walls of the chamber and any propellant will immediately evaporate. The valve (11) can be opened to allow evaporated gas to escape and thereafter close the valve (11). Thereafter, the induction coil (13) is activated to create heat within the chamber and vaporize the drug. The valve (11) is then opened and the patient can inhale the vaporized drug through the mouthpiece (10).

It will be understood that other mechanisms for actuating the release of drug from the container (26) other than the valve lever system (29) can be devised by those skilled in the art. Further, the container (26) can be positioned at different points within the drug delivery device (25). It is desirable to position the container (26) within the device (25) so that the container be readily removed when the contents have been

-34-

emptied, so that a newly charged container can be placed into the device.

In order to demonstrate that the drug delivery device of the present invention can be produced in a variety of different ways, a different embodiment is shown in Figures 5-8. Figure 5 shows a perspective view of a drug delivery device (31). The device (31) is shaped and designed so that it can be held to the user's mouth, like a harmonica, unlike the "pistol" shape shown within Figures 1 and 4. The device (31) is also distinguishable in that it includes a mask (32), which fits over the user's nose and mouth, allowing the vaporized drug to be inhaled through the nostrils and mouth. The device includes a one-way or check valve (33), positioned between the mask (32) and a vaporization chamber (8), similar to the chamber (8) shown in Figures 1 and 4. Like the chamber (8) shown in Figure 1, it is possible to change the configuration to produce the chamber (8) of the type shown within Figure 4, which includes the induction coil heating system. The device includes a power source (2), such as batteries, which is utilized by release of a switch (34) connecting the power source with electrical leads (35). When the switch (34) is actuated, power is supplied to the leads (35) and drug contained (on the walls of the chamber (8) or on any drug dosage unit present) in the system is vaporized.

A cross-sectional side view of the device (31) is shown in Figure 6. A cross-sectional rear view is shown in Figure 7 and a cross-sectional top view is shown in Figure 8.

Figure 9 is a perspective view of a different embodiment of a drug dosage unit (40). The unit (40) is formed into an elongated, rectangular, planar support surface (41) having an electrical resistance path (42)

35

-35-

circuitously positioned thereon. The drug is deposited on the electrical path (42).

Referring back to Figure 5, it can be seen that a plurality of units (40) can be loaded into the device (31). The units (40) are forced toward the chamber (8) by a biasing means such as the springs (43) and (43'). When the drug on a unit (40) has been vaporized, the unit (40) is ejected by using the eject button (36) to force the unit out and allow a new unit (40) to enter the chamber (8).

Method - Drug Delivery by Inhalation

Simple efficient methods of interpulmonary drug delivery can be readily contemplated by using the specific drug-delivery device and drug-delivery dosage unit shown respectively in Figures 1 and 2. The unit (20) shown at Figure 2 is represented schematically by the unit (7) as shown in Figure 1. When such a unit is placed within the chamber (8), it is positioned in electrical connection with the capacitor (4). When the switch (5) is actuated, the power is delivered to the drug on the dosage unit which heats the drug on the dosage unit (7) and converts the drug to a gaseous phase. The valve (11) is opened and the patient inhales through the mouth or nose from the mouthpiece or exhaust tube (10). Because particle size is so small and uniform, the patient can inhale the gaseous drug in the same manner in which smoke from a cigarette is inhaled and bring the gaseous drug deeply into the lungs. The particles will not adhere to the mouth and throat and therefore, the dosage amount delivered to the lungs is accurately controlled, thus eliminating many of the problems present with conventional metered dose inhalers.

The drug delivery device shown within Figure 4 operates in a similar manner. The only difference with

-36-

the device is that the actuation of the switch (5) causes drug first to be released from the container (26) so the drug can be deposited on the surfaces of the chamber (8). The induction coil (13) is then charged so that the drug
5 is heated and vaporized. Thereafter the valve (11) is opened and the patient may inhale the vaporized drug through the mouthpiece (10).

The embodiment shown in Figures 5-8 operates in essentially the same manner as the embodiment shown in
10 Figure 1. The only difference being that the user presses the eject button (36) in order to remove an expended drug dosage unit (40) from the device (31) and allow a new unit (40) to enter the vaporization chamber.

As will be apparent to those skilled in the
15 art, it is possible to interchange the components of these different embodiments. For example, the induction coil (13) shown in Figure 4 could be used in an embodiment such as that shown within Figures 5-8. Further, the mask (32) shown in Figure 5 could be used on
20 the device shown within Figures 1 or 4.

The instant invention is shown and described herein in what is considered to be the most practical and preferred embodiments. It is recognized, however, that departures may be made therefrom which are within the
25 scope of the invention, and that obvious modifications will occur to one skilled in the art upon reading this disclosure.

30

35

-37-

WHAT IS CLAIMED:

1. A method of delivering a drug to a patient, comprising:
- 5 heating a drug to a temperature such that a predetermined amount of the drug is converted to a gaseous phase;
- inhaling gaseous drug into the patient.
- 10 2. The method of claim 1, wherein the heating is carried out by an electrical heating means and the drug is heated to a temperature below its decomposition temperature.
- 15 3. The method of claim 2, wherein the electrical heating means is selected from the group consisting of an induction coil capable of generating high frequency radio energy, a solid state laser, and a coil of electrically conductive wire.
- 20 4. The method of claim 1, wherein the predetermined amount of drug is an amount of 25 milligrams or less.
- 25 5. The method of claim 1, wherein the predetermined amount of drug is an amount in the range of 10 micrograms to 10 milligrams.
- 30 6. The method of claim 1, wherein the drug, prior to heating, is in a solid form at a temperature of 30°C or less.
- 35 7. The method of claim 6, wherein the solid form of the drug is coated in a solid layer on the surface of a substrate comprised of inert material.

-38-

8. The method of claim 7, wherein the drug is coated on the substrate by a means selected from the group consisting of, chemical deposition, vapor deposition, and spraying.

5

9. The method of claim 1, wherein the drug is in a liquid form at a temperature in the range of 15° to 30°C and is dispersed and/or embedded within an inert carrier.

10

10. The method of claim 2, wherein the heating is carried out by passing electrical current through an electrically conductive material positioned relative to the layer of drug such that heat generated in the material is conveyed to the layer of drug in an amount sufficient to create a drug vapor pressure of 0.25 atmospheres of drug or more.

15

11. The method of claim 9, wherein the electrically conductive material is a metal selected from the group consisting of copper, silver, gold and alloys thereof.

20

12. The method of claim 7, wherein the layer of drug is applied to a substrate by a method selected from the group consisting of sputtering and vapor deposition.

25

13. The method of claim 7, wherein the layer of drug is positioned on a substrate, is substantially pure and has a thickness of less than 0.2 mm.

30

35

-39-

14. A drug delivery unit, comprising:
a substrate having a surface; and
a layer of pharmaceutically active drug coated
on the surface, wherein the drug is characterized by
5 generating a vapor pressure of 0.25 atmospheres of
gaseous drug at a temperature of 50°C or more.

15. The unit of claim 14, wherein the drug is
characterized by generating a vapor pressure of 0.5
10 atmospheres at a temperature in the range of 50°C to
350°C.

16. The unit of claim 14, wherein the surface
of the substrate is comprised of an inert material.

17. The unit of claim 14, wherein the surface
of the substrate is comprised of an electrically
conductive material.

20. The unit of claim 14, wherein the layer of
drug has a thickness of less than 0.2 mm.

19. The unit of claim 14, wherein the drug is
substantially pure and the layer of drug has a thickness
25 of less than 0.2 mm.

20. The unit of claim 16, wherein the inert
material is in the form of a glass tube.

30

35

-40-

21. An drug delivery device, comprising:
a heating element;
a drug vaporization chamber;
a mouthpiece in connection with the chamber;
5 a metered dose of a pharmaceutically active
drug positioned in the chamber in a manner such that when
the heating element is activated at least a portion of
the drug is converted to a gaseous phase.
- 10 22. The device of claim 21, wherein the
heating element is in the form of a thin layer of
electrically conductive metal connectable to an
electrical power source.
- 15 23. The device of claim 22, wherein the
metered dose of drug is in the form of a thin layer
coated on a substrate surface.
- 20 24. A drug delivery device comprising:
a heating element;
a drug vaporization chamber;
an opening in connection with the chamber,
which opening can be closed by means of a valve;
a container having a pressurized drug
25 formulation positioned therein, wherein the container has
a valved opening thereon, which opening is in connection
with the drug vaporization, such that when the valve of
the container is opened, drug can be deposited on
surfaces in the drug vaporization chamber.
- 30 25. The device as claimed in claim 24, wherein
the heating element is in the form of an electrical
induction coil.

35

1/4

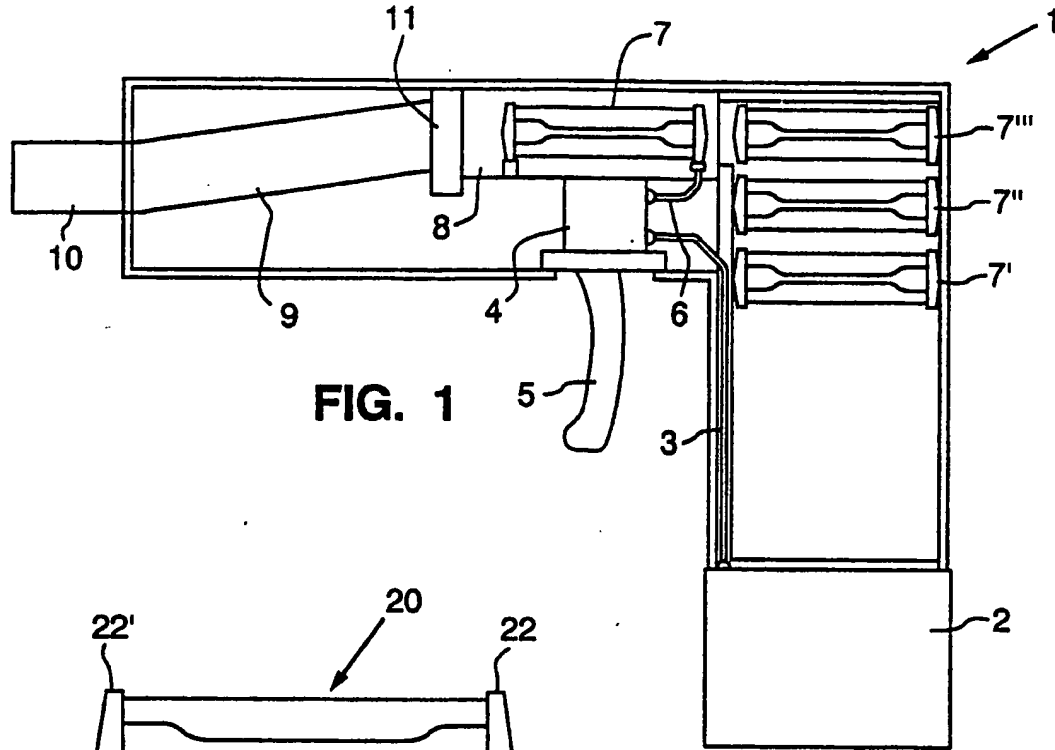

FIG. 1

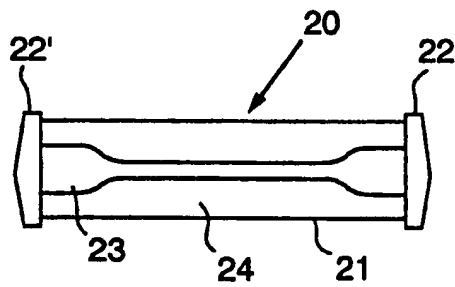

FIG. 2

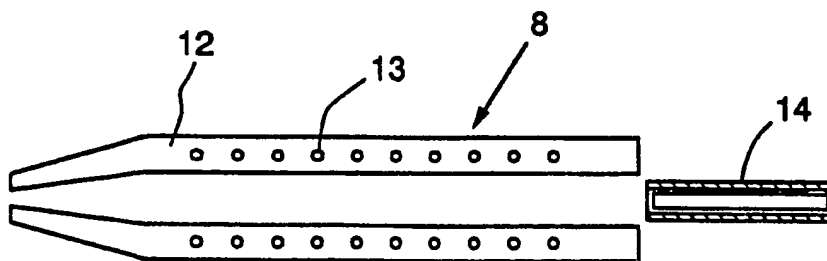

FIG. 3

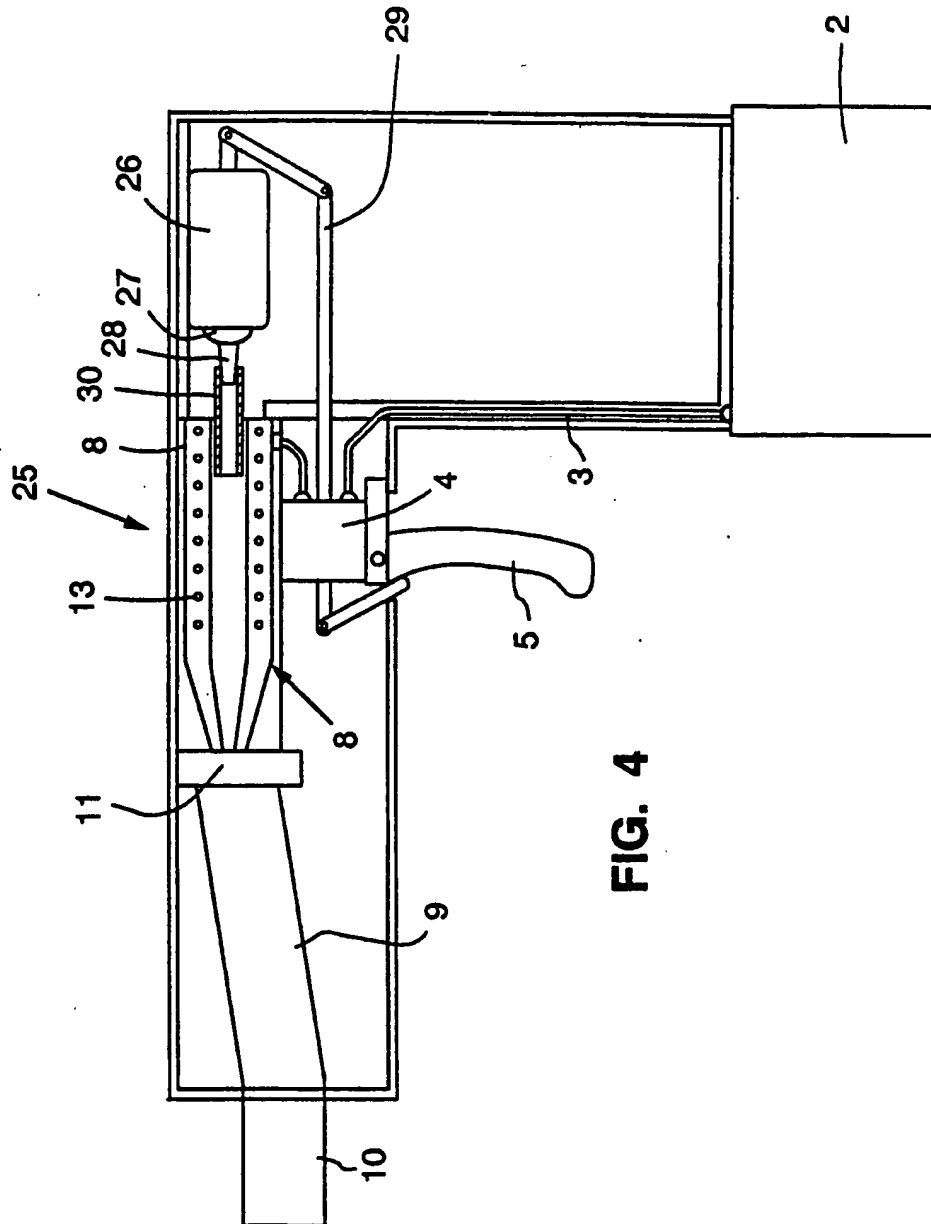

FIG. 4

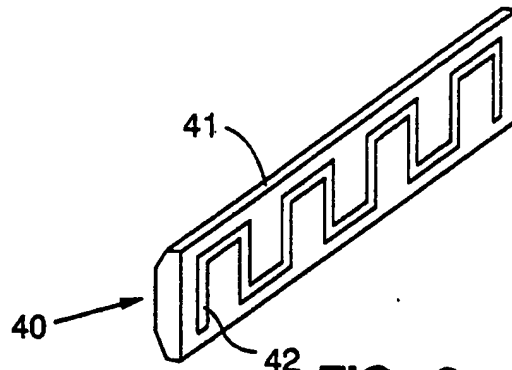

FIG. 9

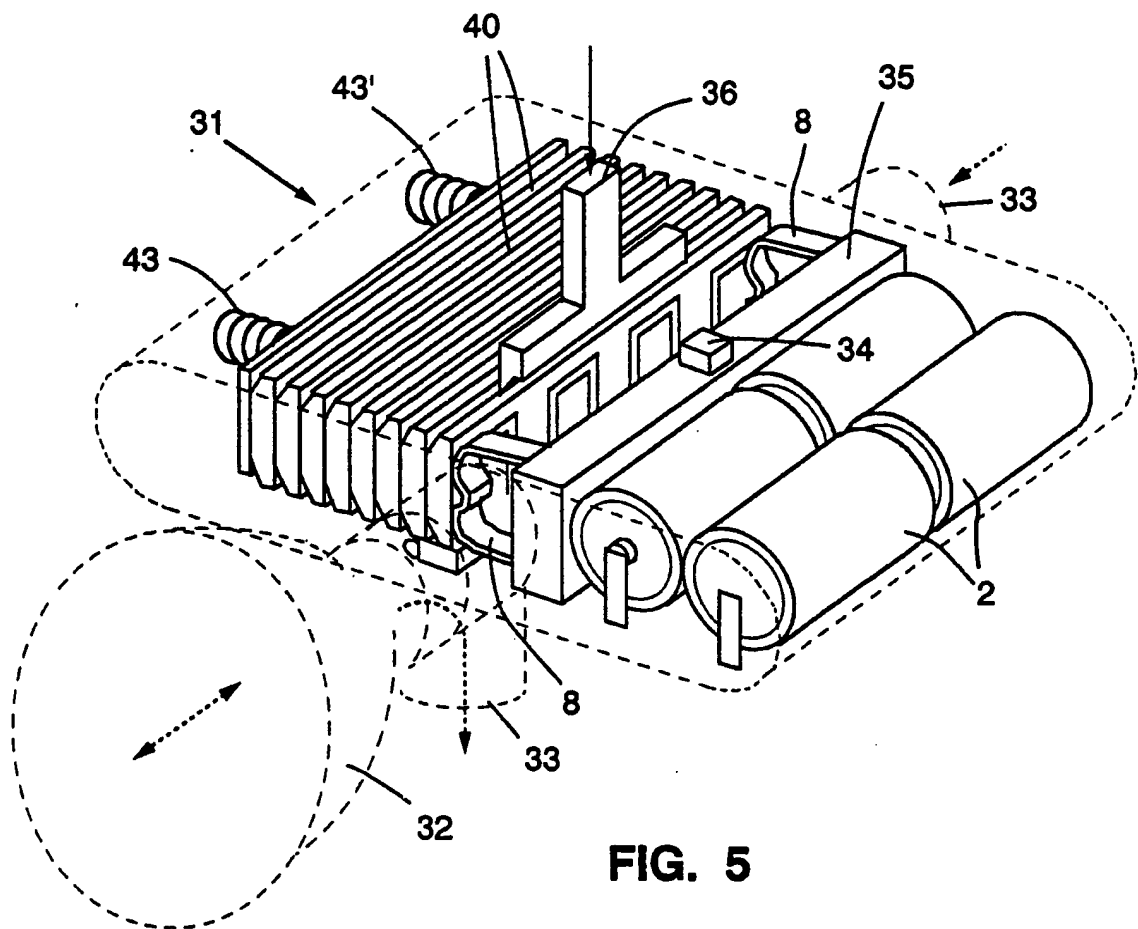

FIG. 5

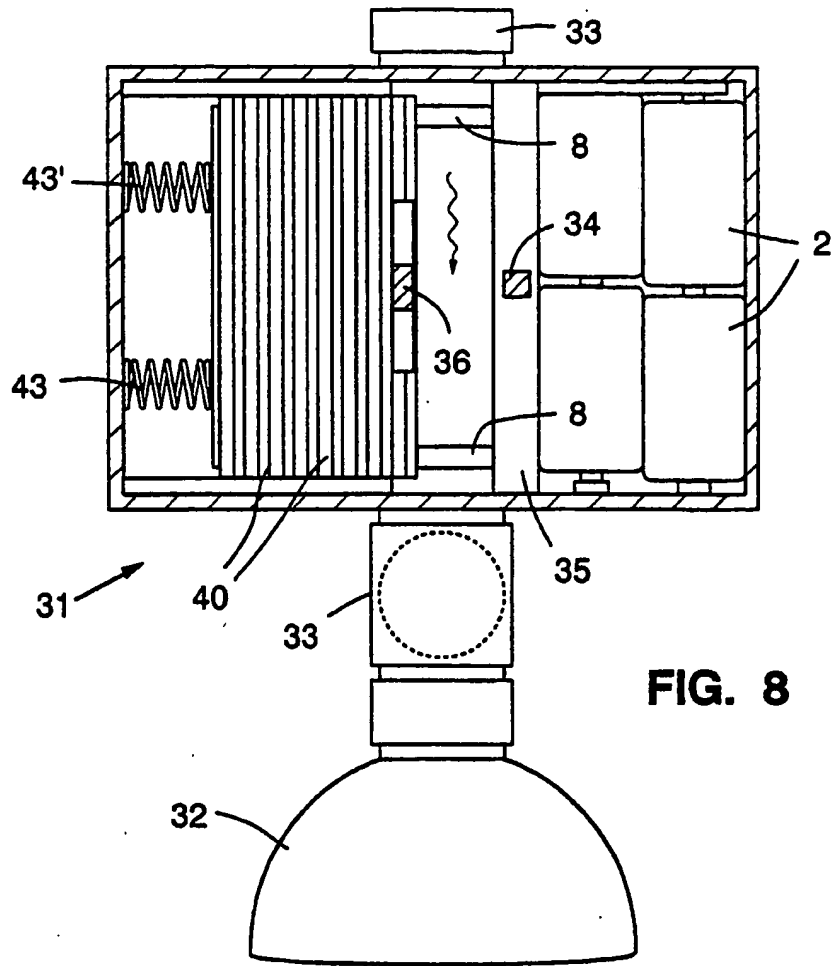

FIG. 8

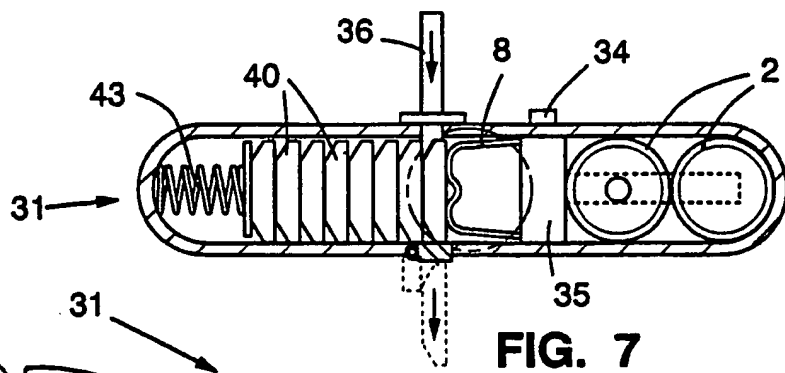

FIG. 7

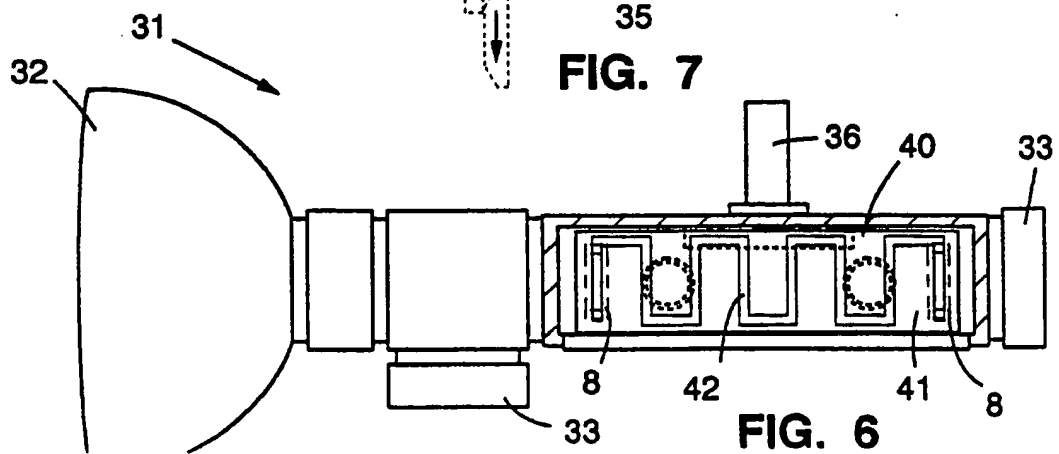

FIG. 6

INTERNATIONAL SEARCH REPORT

International application No.
PCT/US93/09781

A. CLASSIFICATION OF SUBJECT MATTER

IPC(5) : A61M 11/00, 15/00, 16/10
US CL :128/203.12

According to International Patent Classification (IPC) or to both national classification and IPC

B. FIELDS SEARCHED

Minimum documentation searched (classification system followed by classification symbols)

U.S. : 128/203.12, 200.14, 200.23, 203.23, 203.26, 203.27, 204.13

Documentation searched other than minimum documentation to the extent that such documents are included in the fields searched
NONE

Electronic data base consulted during the international search (name of data base and, where practicable, search terms used)
NONE

C. DOCUMENTS CONSIDERED TO BE RELEVANT

Category*	Citation of document, with indication, where appropriate, of the relevant passages	Relevant to claim No.
X ---- Y	US, A, 4922901 (BROOKS ET AL) 08 MAY 1990. SEE ENTIRE DOCUMENT	1-7,9,10,21-23 ----- 8,11-20,24,25
Y	US, A, 1771366 (WYSS ET AL) 22 JULY 1930. SEE ENTIRE DOCUMENT	20
Y	US, A 1485260 (ERNST) 26 FEB 1924. SEE ENTIRE DOCUMENT.	20
A	US, A 4825863 (DITTMAR ET AL) 02 MAY 1989. SEE THE ENTIRE DOCUMENT.	1-20
A	US, A 5144962 (COUNTS ET AL) 08 SEP 1992. SEE THE ENTIRE DOCUMENT.	1-20

Further documents are listed in the continuation of Box C. See patent family annex.

Special categories of cited documents:		
A document defining the general state of the art which is not considered to be part of particular relevance	*T*	later document published after the international filing date or priority date and not in conflict with the application but cited to understand the principle or theory underlying the invention
E earlier document published on or after the international filing date	*X*	document of particular relevance; the claimed invention cannot be considered novel or cannot be considered to involve an inventive step when the document is taken alone
L document which may throw doubts on priority claim(s) or which is cited to establish the publication date of another citation or other special reason (as specified)	*Y*	document of particular relevance; the claimed invention cannot be considered to involve an inventive step when the document is combined with one or more other such documents, such combination being obvious to a person skilled in the art
O document referring to an oral disclosure, use, exhibition or other means		
P document published prior to the international filing date but later than the priority date claimed	*G*	document member of the same patent family

Date of the actual completion of the international search 20 November 1993	Date of mailing of the international search report 26 JAN 1994
Name and mailing address of the ISA/US Commissioner of Patents and Trademarks Box PCT Washington, D.C. 20231	Authorized officer <i>Kimberly L. Asher</i> KIMBERLY L. ASHER
Facsimile No. NOT APPLICABLE	Telephone No. (703) 308 - 0858